

Changing Oil

Refer to *Safety Precautions* on [page 122](#).

RIGHT REAR

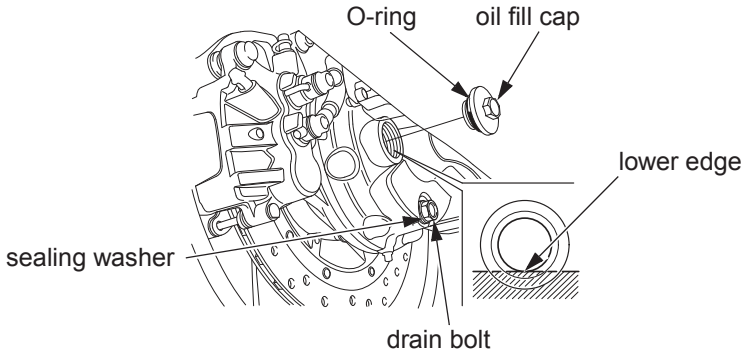

Change the oil with the final drive at normal operating temperature to assure complete and rapid draining.

(Models equipped with center stand)

1. Place the motorcycle on its center stand on a firm, level surface.

(Models not equipped with center stand)

1. Hold the motorcycle upright on firm level ground.

2. Place a drain pan under the drain bolt.

3. Remove the oil fill cap, O-ring, drain bolt and sealing washer.

4. After the oil has completely drained, check that the sealing washer is in good condition. Reinstall the drain bolt with its sealing washer (or a new washer, if necessary) and tighten it to the specified torque:

15 lb·ft (20 N·m, 2.0 kgf·m)

5. Pour the drained oil into a suitable container and dispose of it in an approved manner ([page 189](#)).

NOTICE

Improper disposal of drained fluids is harmful to the environment.

6. Fill the final drive with the recommended oil:

4.1 US oz (120 cm³)

Make sure the final drive oil level is at the lower edge of the oil fill inspection hole.

7. Install the oil fill cap, a new O-ring and tighten it to the specified torque:

9 lb·ft (12 N·m, 1.2 kgf·m)