

Checking & Adding Coolant

Refer to *Safety Precautions* on [page 122](#).

LEFT SIDE

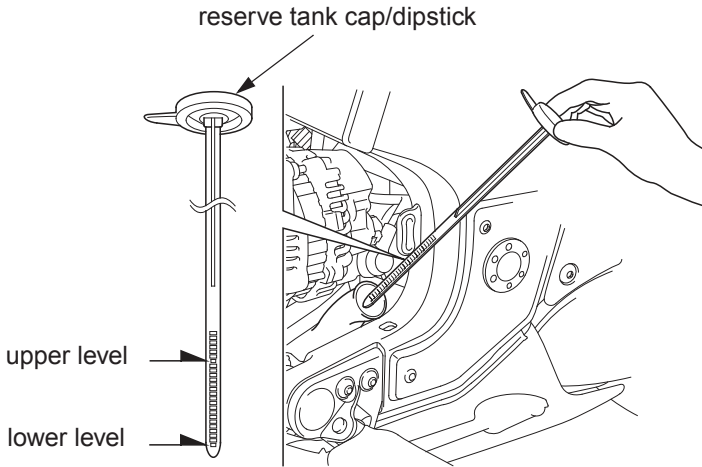

1. Remove the left engine side cover ([page 136](#)).
(Models equipped with center stand)
2. Park your motorcycle on its center stand on a firm, level surface.
(Models not equipped with center stand)
2. Hold the motorcycle upright on firm level ground.
3. With the engine at normal operating temperature, remove the reserve tank cap/dipstick and check the coolant level.
If the reserve tank is empty, or if coolant loss is excessive, check for leaks and see your dealer for repair.
4. Add coolant to the reserve tank as required to bring the coolant level to the upper level mark.
Always add coolant to the reserve tank. Do not attempt to add coolant by removing the radiator cap.
5. Reinstall the left engine side cover.