

Damper Oil Change

1. Check the fork center bolt lock nut (1) is installed on the fork damper piston rod (2) properly.

NOTICE

If the lock nut was removed, the piston rod will fall into the fork damper and you will not be able to reassemble the fork damper.

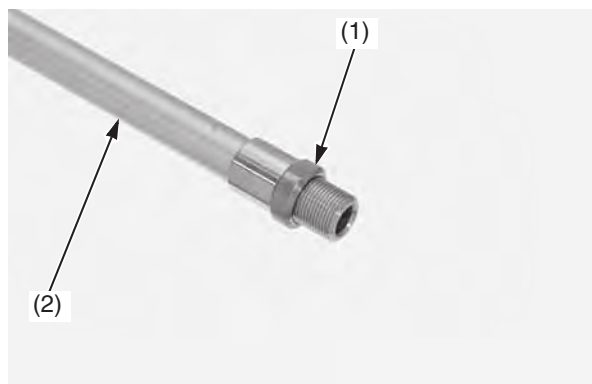

- (1) fork center bolt lock nut
(2) fork damper piston rod

2. Loosen the fork bolt assembly (3) while holding the fork damper assembly (4).

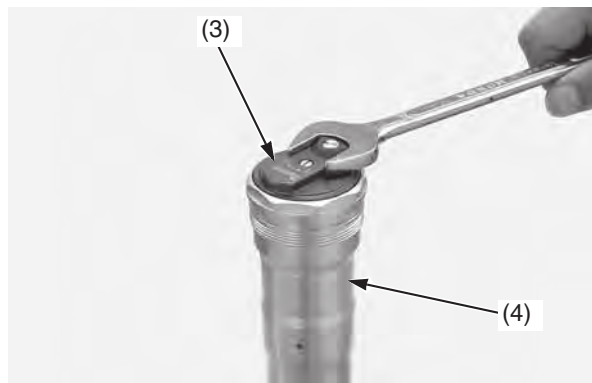

- (3) fork bolt assembly (4) fork damper assembly

3. Remove the fork bolt assembly (3) from the fork damper threads and then pop it out by pumping the fork damper piston rod (2) slowly.
4. Remove the fork bolt assembly (3).

Be careful not to damage the fork bolt bushings. Do not disassemble the fork bolt assembly. Replace the fork bolt as an assembly if it is damaged.

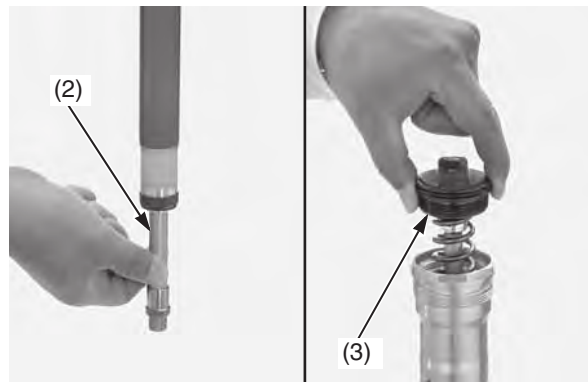

- (2) fork damper piston rod (3) fork bolt assembly

5. Empty the fork oil from the fork damper assembly (4) by pumping the damper rod several times.

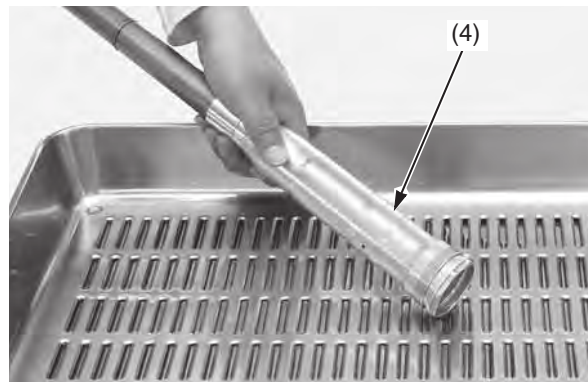

- (4) fork damper assembly

6. Clean the fork bolt and fork damper assembly threads (5).

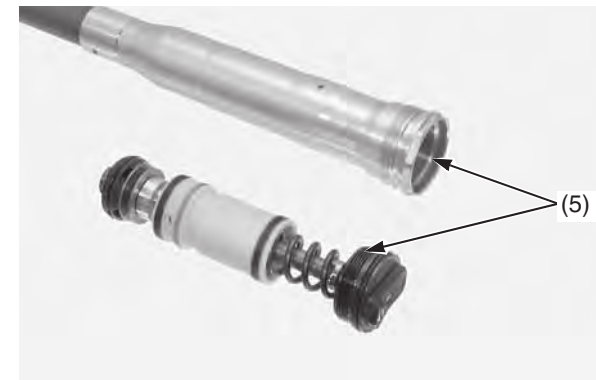

- (5) fork bolt and fork damper assembly threads

7. Extend the fork damper piston rod to maximum length.
Pour the recommended fork oil into the fork damper assembly (4).
Recommended Oil:
Pro Honda HP Fork Oil, SS-19
Recommended Amount:
8.4 US oz (248 cm³)

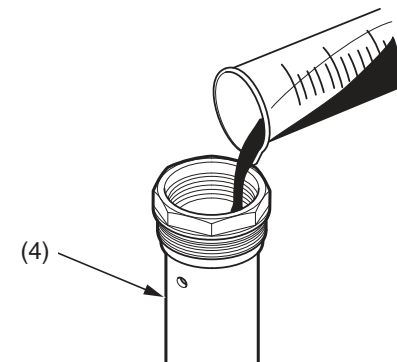

- (4) fork damper assembly

(cont'd)