

18. While keeping the forks parallel, alternately tighten the right axle pinch bolts (31) to the specified torque:
15 lbf-ft (20 N·m, 2.0 kgf·m)

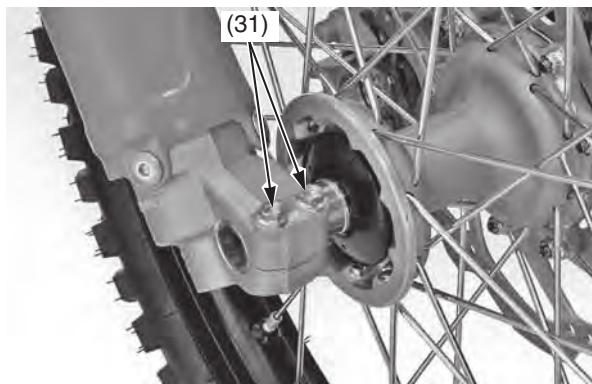

(31) right axle pinch bolts

NOTICE

To avoid damage when torquing the axle pinch bolts, be sure the axle is seated firmly onto the left fork leg clamp inner surface.

19. Install the disc cover (32) and tighten the disc cover socket bolts (33) to the specified torque:
10 lbf-ft (13 N·m, 1.3 kgf·m)

NOTICE

Do not ride with the disc cover removed. Doing so may damage the speed sensor wire.

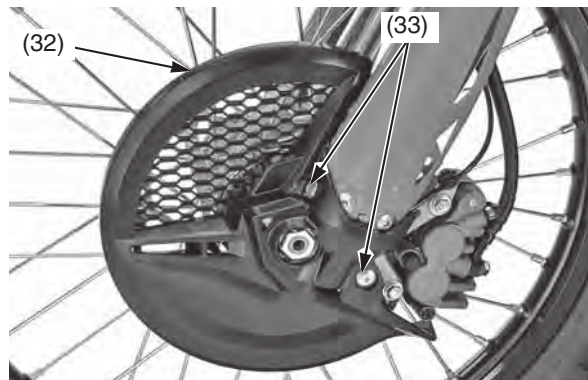

(32) disc cover

(33) disc cover socket bolts

20. Turn the compression damping (34) and rebound damping (35) adjuster screws back to their original settings.

Refer to *Front Suspension Damping* on page 145.

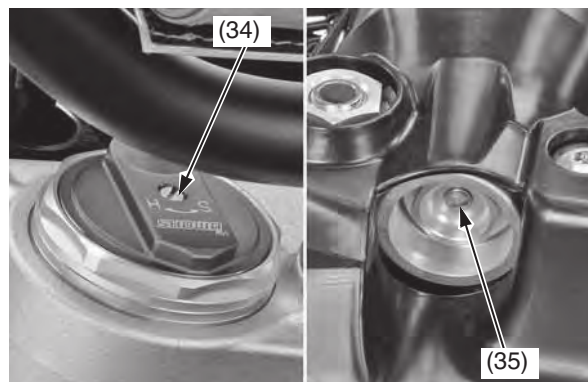

(34) compression damping adjuster

(35) rebound damping adjuster

Fork Damper Disassembly

1. Remove the front suspension (page 106).
2. Disassemble the fork outer tube (page 108).
3. Place the lower end (axle holder) (1) of the slider in a vise with a piece of wood or soft jaws to avoid damage.

NOTICE

Over-tightening the vise can damage the axle holder.

4. Loosen the fork center bolt (2).

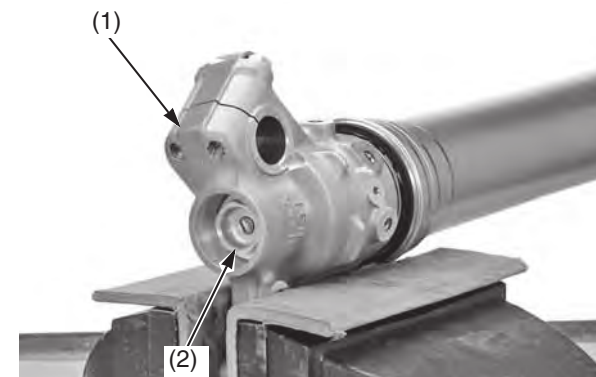

(1) axle holder

(2) fork center bolt

5. Pull up the fork outer tube slowly and temporarily tighten the fork damper assembly (page 109). Push the outer tube until the fork center bolt lock nut (3) is fully exposed and install the piston base (4) or mechanic's stopper tool between the axle holder (1) and fork center bolt lock nut.

- Piston base 07958-2500001

(cont'd)