

Suspension

Front Suspension Installation

1. Insert both fork legs into the fork clamps.
Tighten the fork bridge lower pinch bolts (1) to the specified torque:
15 lbf-ft (20 N·m, 2.0 kgf·m)



(1) fork bridge lower pinch bolts

2. Tighten the fork damper assembly (2) to the specified torque using the lock nut wrench (3):
Actual:
56 lbf-ft (76 N·m, 7.7 kgf·m)
Torque wrench scale reading:
51 lbf-ft (69 N·m, 7.0 kgf·m), using a 20 in (500 mm) long deflecting beam type torque wrench.

- Lock nut wrench 07WMA-KZ30100

When using the lock nut wrench, use a 20 in (500 mm) long deflecting beam type torque wrench. The lock nut wrench increases the torque wrench's leverage, so the torque wrench reading will be less than the torque actually applied to the fork damper assembly.

3. Tighten the fork bolt assembly (4) to the specified torque:
22 lbf-ft (30 N·m, 3.1 kgf·m)

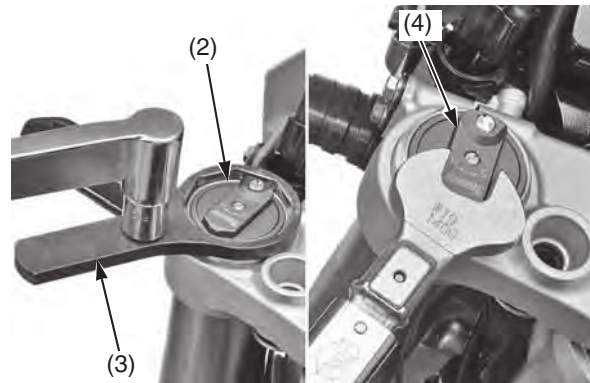

(2) fork damper assembly
(3) lock nut wrench
(4) fork bolt assembly

4. For ease of releasing air pressure after the forks are installed, loosen the fork bridge lower pinch bolts (1) and position the outer tubes so that the fork air pressure release screws (5) are in front of the compression damping adjuster (6).

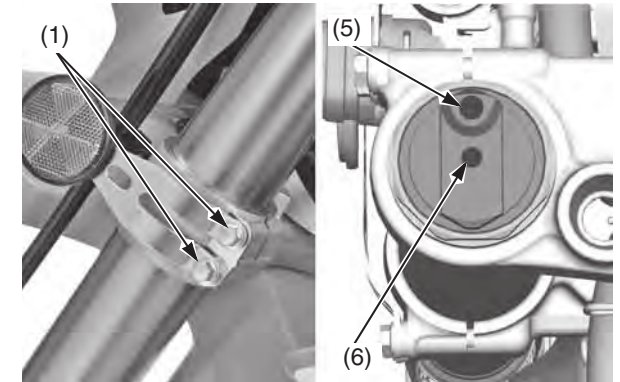

(1) fork bridge lower pinch bolts
(5) pressure release screw
(6) compression damping adjuster

5. Align the groove (7) in the outer tube with the top surface of the upper fork bridge (8).

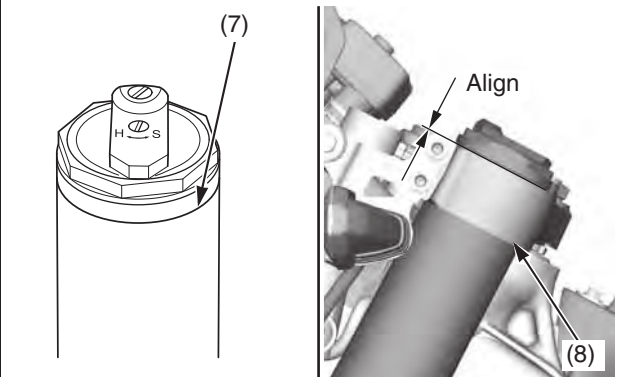

(7) groove

(8) upper fork bridge