

# Clutch System

## Clutch Disc/Plate Removal

1. Drain the engine oil (page 65).
2. Remove the clutch cover A bolts (1), washer (2), clutch cover B bolt (3), clutch cover C bolts (4) and clutch cover (5).

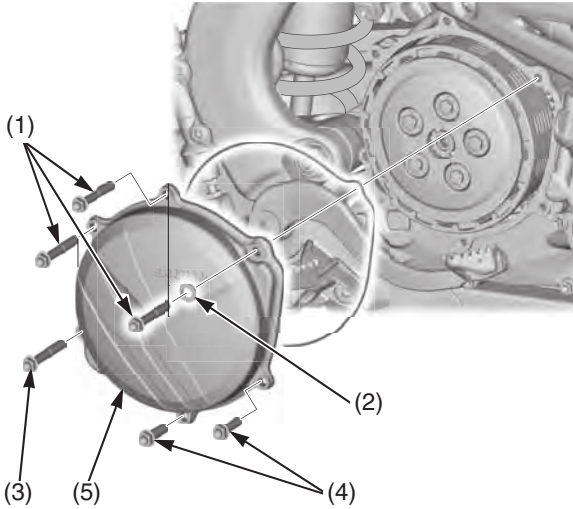

- (1) clutch cover A bolts      (4) clutch cover C bolts  
(2) washer                      (5) clutch cover  
(3) clutch cover B bolt

3. Remove the five clutch spring bolts and springs (6).

Loosen the bolts in a crisscross pattern in two or three progressive steps.

4. Remove the clutch pressure plate (7).

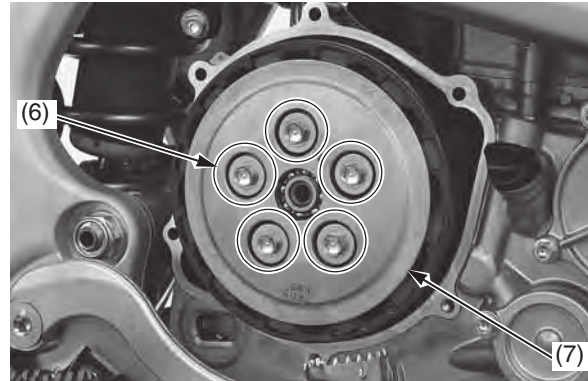

- (6) clutch spring bolts and springs  
(7) clutch pressure plate

5. Check the operation of the bearing (8) with your finger. The bearing should turn smoothly and quietly.

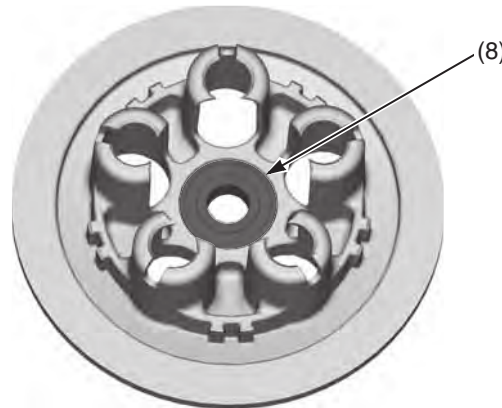

- (8) bearing

If the operation is not smooth, refer to an official Honda Service Manual (page 186) for bearing disassembly or see your dealer.

6. Remove the clutch lifter (9) first, then remove the clutch lifter rod (10).

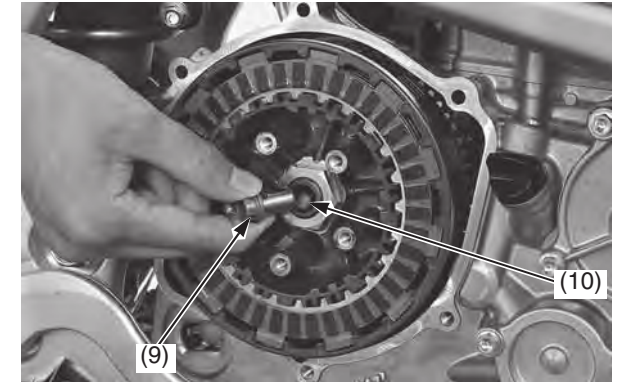

- (9) clutch lifter

- (10) clutch lifter rod

7. Remove the eight clutch discs, seven clutch plates, judder spring and spring seat (11).

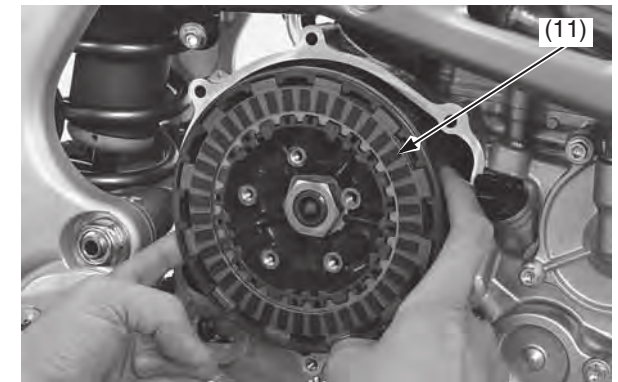

- (11) clutch discs, clutch plates, judder spring and spring seat