

Starting & Stopping the Engine

Warm Engine Starting

1. Shift the transmission into neutral.
2. Pull the clutch lever all the way in, and depress the start button. (Do not open the throttle.)

Starting the engine excessively charged with fuel by throttle blipping or other reasons

1. Shift the transmission into neutral.
2. With the throttle fully opened, pull the clutch lever all the way in, and depress the start button for 5 seconds to discharge excessive fuel from the engine.
3. Pull the clutch lever all the way in, and depress the start button. (Do not open the throttle.)

Snapping the throttle or fast idling for more than about 5 minutes may cause exhaust pipe and muffler discolorations.

When starting the engine, the MIL (amber) will stay on for 2 seconds, then go off. And then the engine mode indicator (blue) indicates the current engine mode for 0.8 seconds, then goes off. If the MIL/engine mode indicator (1) does not come on or go off when it should, have your dealer check it for problems.

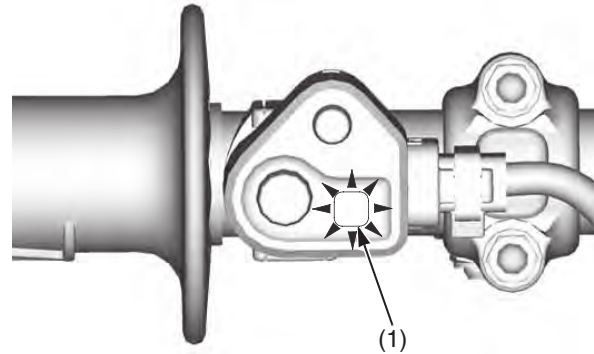

(1) MIL (amber) / engine mode indicator (blue)

How to Stop the Engine

Normal Engine Stop

1. Shift the transmission into neutral.
2. Push and hold the engine stop button (1) until the engine stops completely.

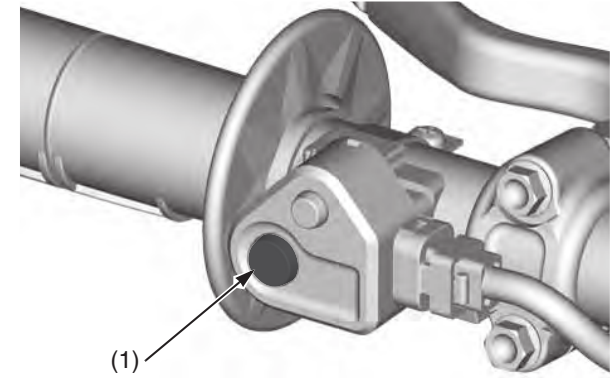

(1) engine stop button

Emergency Engine Stop

To stop the engine in an emergency, push and hold the engine stop button.