

Fuel Pressure Relieving

1. Disconnect the fuel pump sub-harness connector (1).

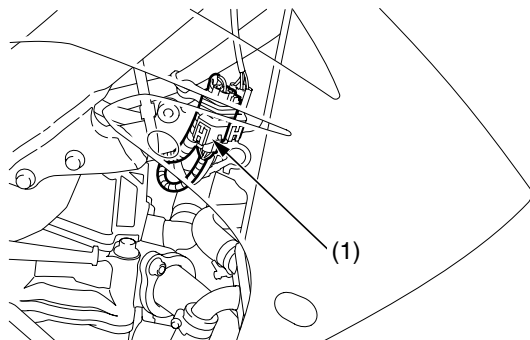

(1) fuel pump sub-harness connector

2. Start the engine and let it idle until the engine stalls.

Fuel Line Replacement

Disconnection

1. Relieve the fuel pressure (this page).
2. Hang the fuel tank to the left side of the frame (page 34).
3. Remove the fuel quick connect fitting cover (1) from the fuel pump (2).
4. Check the fuel quick connect fitting (3) for dirt, and clean if necessary.

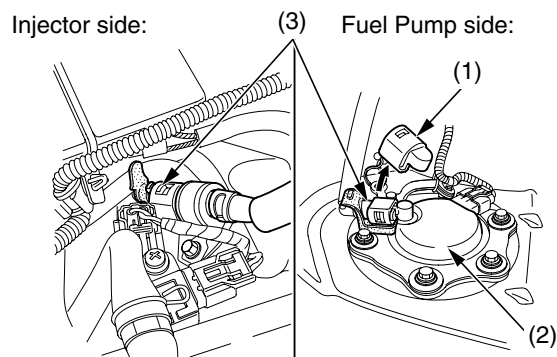

(1) fuel quick connect fitting cover
(2) fuel pump
(3) fuel quick connect fitting

5. Remove the bolt (4), clamp and setting rubber (5).

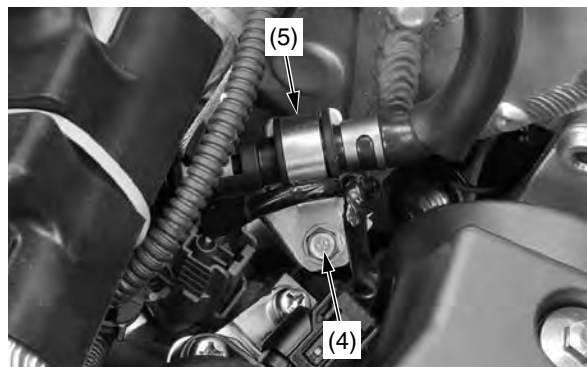

(4) bolt (5) clamp and setting rubber

6. Pull and release the joint rubber (6) of the injector side from the retainer (7).

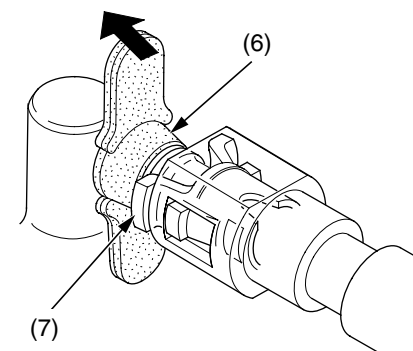

(6) joint rubber (injector side only)
(7) retainer

7. Place a shop towel (8) over the fuel quick connect fitting.

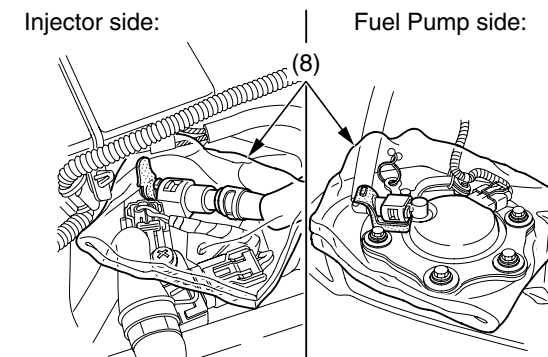

(8) shop towel

(cont'd)