

# Throttle

---

## Throttle Inspection

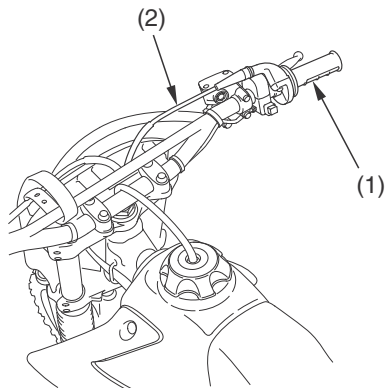

- (1) throttle
- (2) throttle cables

1. Check that the throttle assembly is positioned properly and the securing bolts are tight.

2. Check for smooth rotation of the throttle (1) from fully open to fully closed in all steering positions. If there is a problem, see your dealer.
3. Inspect the condition of the throttle cables (2) from the throttle grip down to the carburetor. If the cable is kinked or chafed, have it replaced.
4. Check the cables for tension or stress in all steering positions.
5. Lubricate the cables with a commercially available cable lubricant to prevent premature rust and corrosion.