

Engine Oil

Changing Engine Oil

UNDER ENGINE

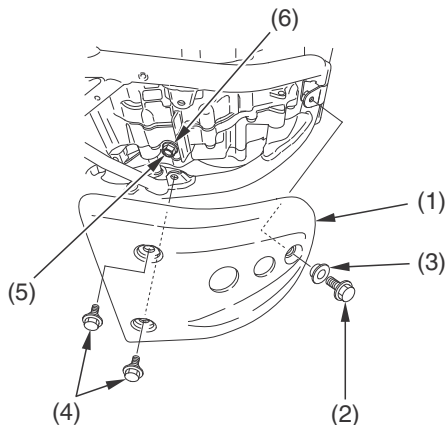

- (1) engine guard
- (2) bolt A
- (3) collar
- (4) bolts B
- (5) oil drain bolt
- (6) sealing washer

1. Remove the engine guard (1) by removing the bolt A (2), collar (3) and bolts B (4).
2. If the engine is cold, start it and let it idle for 3-5 minutes. Turn the engine off. Wait 2-3 minutes for the oil to settle.
3. Park your motorcycle on its side stand on a firm, level surface.
4. Place a drain pan under the crankcase.
5. To drain the oil, remove the oil fill cap/ dipstick, oil drain bolt (5), and sealing washer (6).
6. Pour the drained oil into a suitable container and dispose of it in an approved manner ([page 129](#)).

NOTICE

Improper disposal of drained fluids is harmful to the environment.