

5. Check that the drain plug sealing washer is in good condition and reinstall the oil drain plug securely, then fill the crankcase with approximately 2.1 liters (2.2 US qt) of the recommended oil.
6. Reinstall the oil filler cap.
7. Start the engine and let it idle for a few minutes.
8. Stop the engine and make sure that oil level is between the upper and lower marks on the dipstick. If necessary, add more oil but do not overfill.

CAUTION:

- * *Running the engine with improper oil level can cause serious engine damage.*

CARBURETOR CHOKE

Inspect the choke cable (1) for condition and choke lever (2) for operation. Replace the cable if it is damaged or kinked.

Lubricate the cable with commercially available cable lubricant to prevent premature wear and corrosion.

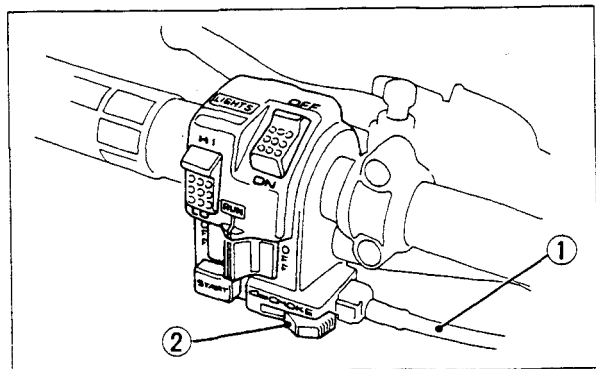

(1) Choke cable

(2) Choke lever