

Starting Procedure (after Preparation)

To restart a warm engine, follow the procedure for High Air Temperature.

CAUTION:

- * Do not push the starting primer knob under Normal Air Temperature or High Air Temperature, or the engine will be flooded with excess fuel. This will result in engine starting difficulties.

Normal Air Temperature

10°—35°C (50°—95°F):

1. While pushing the choke lever (6) in, move it to detent position “B.”
2. Keep the throttle fully closed.
3. Press the starter button (7) and start the engine.

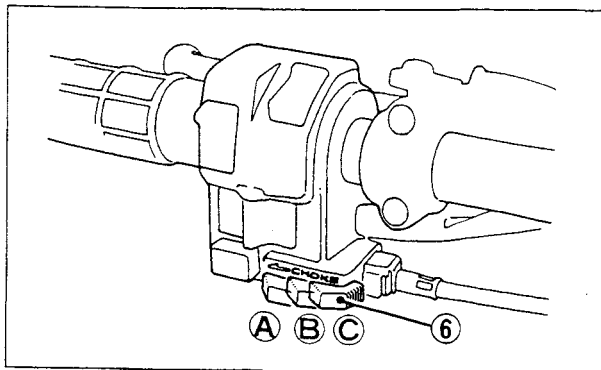

(6) Choke lever

NOTE:

- * Do not use the electric starter for more than 5 seconds at a time. Release the starter button for approximately 10 seconds before pressing it again.
 - * To prevent a weak or discharged battery, use the kickstarter if you encounter any difficulty in cranking the engine with the starter motor.
 - * The starter motor will operate only when the transmission is in neutral.
4. After the engine starts, continue warming up the engine until it will idle smoothly with the choke lever, in detent position “B.” Then push the choke lever all the way to “Fully Closed position (C).” If idle is instable open the throttle slightly.

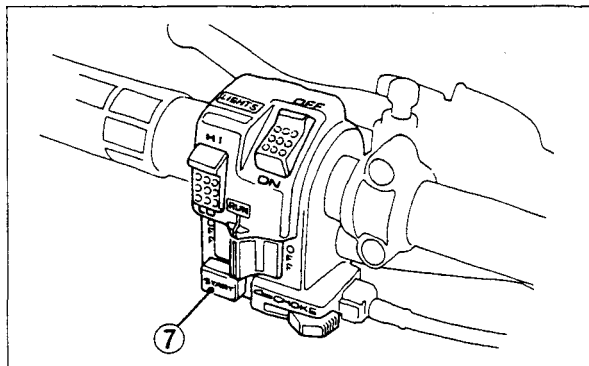

(7) Starter button