

# MAINTENANCE

---

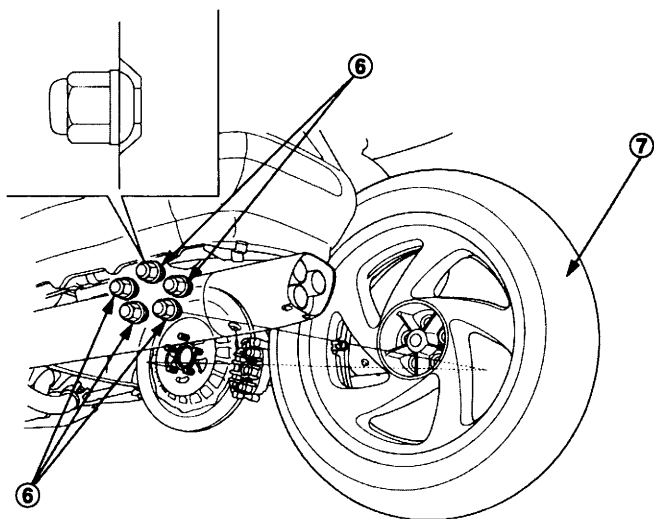

## Installation

1. Reassemble the removed parts in the reverse order of removal.
2. Tighten the rear wheel nuts to the specified torque:  
80 lbf·ft (108 N·m, 11.0 kgf·m)
3. After installing the wheel, apply the brake several times and then check if the wheel rotates freely. Recheck the wheel if the brake drags or if the wheel does not rotate freely.
4. Operate the brake pedal and check the brake operation.
5. Inspect the brake system (page 160).

If a torque wrench was not used for installation, see your Honda dealer as soon as possible to verify proper assembly. Improper assembly may lead to loss of braking capability.